

Varenummer: 0109047  
 Beskrivelse: Seeger låsering AS 30X2.0  
 Fjederstål  
 Note: Monteres med ZGA tang

## Mål

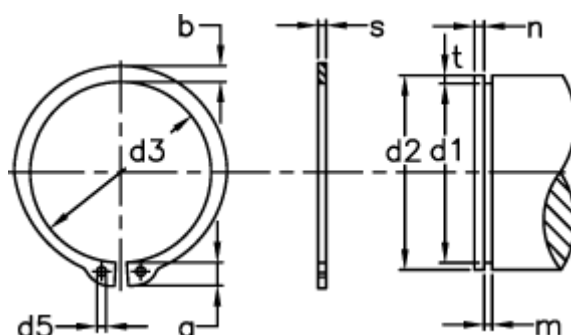

a max	= 6.5	d5 min	= 2.0	s	= 2.00
AN mm <sup>2</sup>	= 64.4	FN kN	= 10.70	t	= 0.70
B	= 1.78	FRg kN	= 13.6	Tang	= ZGA-2
b	= 4.1	FR kN	= 57.0	tol	= -0.07
Betegnelse	= AS 30	g	= 1.5	tol	= +0,21 -0,42
d1	= 28.6	m min	= 2.15	tol	= -0.21
d2	= 30	n abl x 1000	= 21	vægt kg/1000	= 5.00
d3	= 27.9	Nominel træk	= 2.1		